

## ◎ POWER RATING

Engine Speed rev/min	Type of Operation	Engine Power	
		kWm	Ps
<b>1800</b>	<b>Prime Power</b>	<b>150</b>	<b>204</b>
	<b>Standby Power</b>	<b>165</b>	<b>224</b>
<b>1500</b>	<b>Prime Power</b>	<b>128</b>	<b>174</b>
	<b>Standby Power</b>	<b>141</b>	<b>191</b>

Note : -. The engine performance corresponds to ISO 3046, BS 5514 and DIN 6271.

\* Without cooling fan, inter cooler inlet water temperature 32 °C

-. Ratings are based on ISO 8528.

→ **Prime power** available at variable load. The permissible average power out put (during 24h period) shall not exceed 70% of the prime power rating. No overload is permitted.

→ **Standby power** available in the event of a main power network failure. No overload is permitted.

## ◎ MECHANICAL SYSTEM

○ Engine Type	In-line 4 cycle, water cooled
	Turbo charged & intercooled (water to air)
○ Combustion type	Stoichiometric, Premixed and spark ignited
○ Cylinder Type	Replaceable dry liner
○ Number of cylinders	6
○ Bore x stroke	111(4.37) x 139(5.47) mm(in.)
○ Displacement	8.071 (492.52) lit.(in <sup>3</sup> )
○ Compression ratio	10.5 : 1
○ Firing order	1-5-3-6-2-4
○ Ignition timing	13° BTDC
○ Compression pressure	Above 16 kg/cm <sup>2</sup> (228 psi) at 200rpm
○ Dry weight	Approx. 820 kg (1,808 lb)
○ Dimension (LxWxH)	1,415 x 925 x 1,400 mm (56 x 37 x 56 in.)
○ Rotation	Counter clockwise viewed from Flywheel
○ Fly wheel housing	SAE NO.2
○ Fly wheel	Clutch NO.11 1/2

## ◎ MECHANISM

○ Type	Over head valve
○ Number of valve	Intake 1, exhaust 1 per cylinder
○ Valve lashes at cold	Intake 0.30mm (0.0118 in.) Exhaust 0.30mm (0.0118 in.)

## ◎ VALVE TIMING

	Opening	Close
○ Intake valve	16 deg. BTDC	36 deg. ABDC
○ Exhaust valve	46 deg. BBDC	14 deg. ATDC

## ◎ FUEL CONSUMPTION

		1,500 rpm	1,800 rpm
○ Prime (Nm <sup>3</sup> /hr)			
	25%	13.3	13.9
	50%	17.8	21.8
	75%	24.3	29.9
	100%	31.8	38.5
○ Standby (Nm <sup>3</sup> /hr)			
	25%	12.8	15.7
	50%	20.1	25.4
	75%	28.2	34.7
	100%	36.0	42.3

## ◎ FUEL SYSTEM

○ Carburetor	Impco 200M Varifuel carburetor
○ Gas regulator	Maxitrol RV61
○ Max. inlet pressure	1.0 psi at the engine inlet

## ◎ LUBRICATION SYSTEM

○ Lub. Method	Fully forced pressure feed type
○ Oil pump	Gear type driven by crankshaft
○ Oil filter	Full flow, cartridge type
○ Oil pan capacity	High level 23 liters ( 6.08 gal.) Low level 17 liters ( 4.49 gal.)
○ Lub. Oil	Refer to Operation Manual Low ash type(0.5wt%) natural gas engine oil API service grade CD or higher SAE 15W-40

## ◎ COOLING SYSTEM

○ Cooling method	Fresh water forced circulation
○ Water capacity (engine only)	18 liters ( 4.76 gal.)
○ Pressure system	Max. 0.5 kg/cm <sup>2</sup> ( 7.1 psi)
○ Water pump	Centrifugal type driven by belt
○ Cooling fan	Blower, 660.4mm diameter, 7 blades Plastic
○ Loss power of fan	6.8PS (5kW) @ Eng. Speed 1,500 rpm 10.9PS (8kW) @ Eng. Speed 1,800 rpm
○ Thermostat	Wax – pellet type Opening temp. 71°C Full open temp. 85°C

## ◎ ELECTRICAL SYSTEM

○ Charging generator	24V x 45A alternator
○ Voltage regulator	Built-in type IC regulator
○ Starting motor	24V x 4.5kW
○ Battery Voltage	24V
○ Battery Capacity	150 AH (recommended)
○ Ignition controller	12 or 24V DC (min 8V DC at start, 32V DC max)

## ◎ IGNITION SYSTEM

○ Spark plug	NGK IFR7B-D, 0.4mm air gap Champion RC78PYP, 0.38mm air gap
○ Ignition controller	Altronic CD 1 unit (12 or 24V DC)
○ Ignition coil	Altronic 501 061 blue epoxy individual coil
○ Trigger system	Magnetic pick-up sensor and trigger wheel and Hall-effect ( 0.75 ~ -0.25mm air gap)

## ◎ ENGINEERING DATA

○ Water flow	200 liters/min @1,500 rpm 240 liters/min @1,800 rpm
○ Heat rejection to coolant	32.9 kcal/sec @1,500 rpm 39.3 kcal/sec @1,800 rpm
○ Heat rejection to CAC	1.3 kcal/sec @1,500 rpm 2.6 kcal/sec @1,800 rpm
○ Intercooler water flow	302.4 liters/min @1,500 rpm 362.9 liters/min @1,800 rpm
○ Air flow	10.3 m <sup>3</sup> /min @1,500 rpm 12.5 m <sup>3</sup> /min @1,800 rpm
○ Exhaust gas flow	16.5 m <sup>3</sup> /min @1,500 rpm 20.3 m <sup>3</sup> /min @1,800 rpm
○ Exhaust gas temp.	540 °C @1,500 rpm 560 °C @1,800 rpm
○ Radiator air flow	210 m <sup>3</sup> /min @1,500 rpm, 0.7kPa 270 m <sup>3</sup> /min @1,800 rpm, 1.0kPa
○ Max. permissible restrictions	
-Intake system	220 mmH <sub>2</sub> O initial 635 mmH <sub>2</sub> O final
-Exhaust system	600 mmH <sub>2</sub> O max.
○ Altitude Capability	1,000 m

## ◆ CONVERSION TABLE

in. = mm x 0.0394	lb/ft = N.m x 0.737
PS = kW x 1.3596	U.S. gal = lit. x 0.264
psi = kg/cm <sup>2</sup> x 14.2233	kW = 0.2388 kcal/s
in <sup>3</sup> = lit. x 61.02	lb/PS.h = g/kW.h x 0.00162
hp = PS x 0.98635	cfm = m <sup>3</sup> /min x 35.336
lb = kg x 2.20462	Nm <sup>3</sup> = SCF × 0.0283
Kg/hr = Nm <sup>3</sup> /hr × 0.732 (natural gas)	
Btu/ft <sup>3</sup> = MJ/m <sup>3</sup> × 26.8392 (natural gas)	
kPa = 101.97 mmH <sub>2</sub> O = 0.01 bar	

© Dimensions : Engine

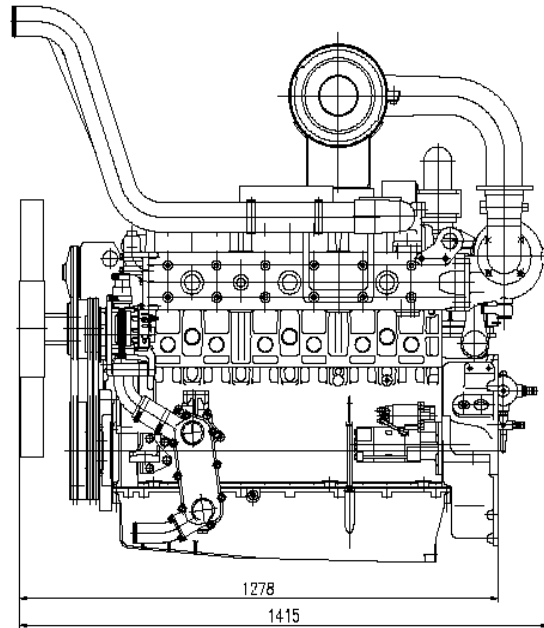
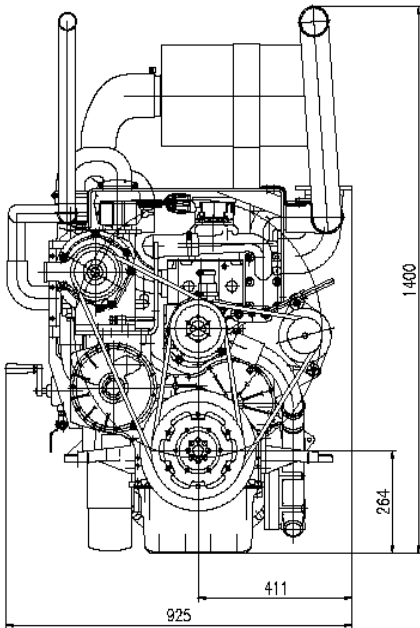

© Dimensions : Gen-pack

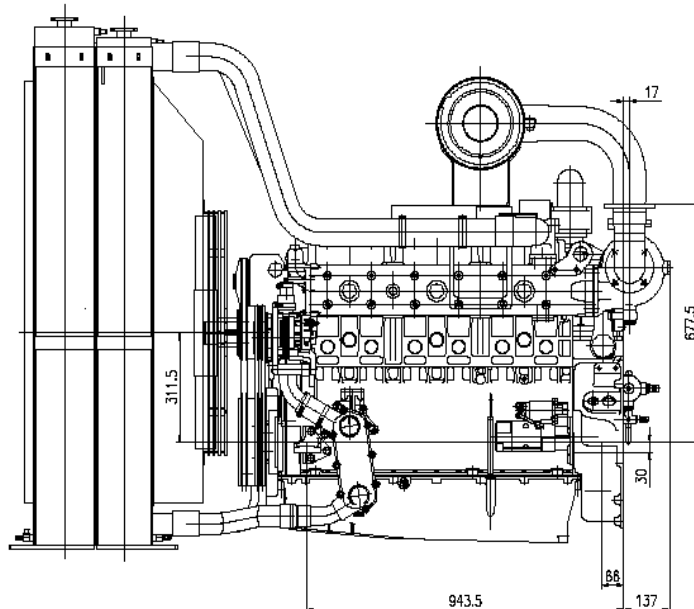
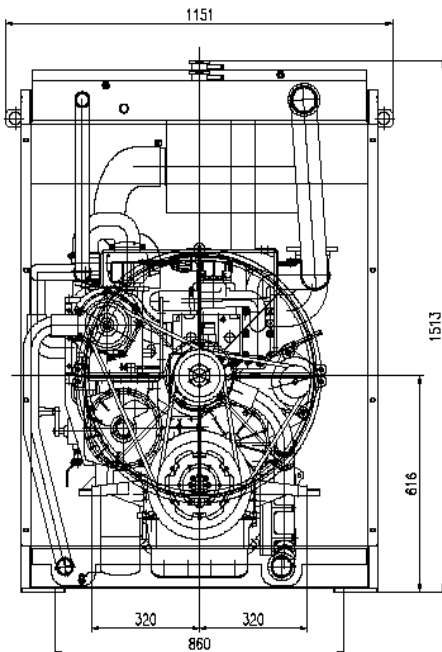

**Doosan Infracore Co., Ltd.**

21st Floor, Doosan Tower, 18-12, Euljiro 6-ga,  
Jung-gu, Seoul, Korea

TEL : +82-2-3398-8400 / Fax : +82-2-3398-8509

E-mail : [enginesales@doosan.com](mailto:enginesales@doosan.com)

Web site : [www.doosaninfracore.com](http://www.doosaninfracore.com)

※ Specifications are subject to change without prior notice